

TRICOM 10G SFP+ DUAL FIBER

20KM Tx1310nm

Product Description

This 1310nm Dual Fiber 10Gigabit SFP+ transceiver is designed to transmit and receive optical data over single mode optical fiber for link length 10km/20km. The SFP+ LR module electrical interface is compliant to SFI electrical specifications. The transmitter input and receiver output impedance is 100 Ohms differential. Data lines are internally AC coupled. The module provides differential termination and reduce differential to common mode conversion for quality signal termination and low EMI. SFI typically operates over 200 mm of improved FR4 material or up to about 150mm of standard FR4 with one connector.

Features

- Fiber Bi-Directional SFP+ Optical Transceiver
- Optical interface compliant to IEEE 802.3ae 10GBASE-LR
- Electrical interface compliant to SFF-8431
- Hot Pluggable
- 1310nm DFB transmitter, PIN photo-detector
- Operating case temperature: 0 to 70 °C
- Low power consumption
- Applicable for 10km/20km SMF connection
- All-metal housing for superior EMI performance
- Advanced firmware allows customer system encryption information to be stored in transceiver
- Cost effective SFP+ solution, enables higher port densities and greater bandwidth

Applications

- 10Gbps Ethernet or SONET/SDH switches and routers
- 10G/8.5G/4.25G/2.125G/1.0625G Fiber Channel
- Other 10Gbps optical links

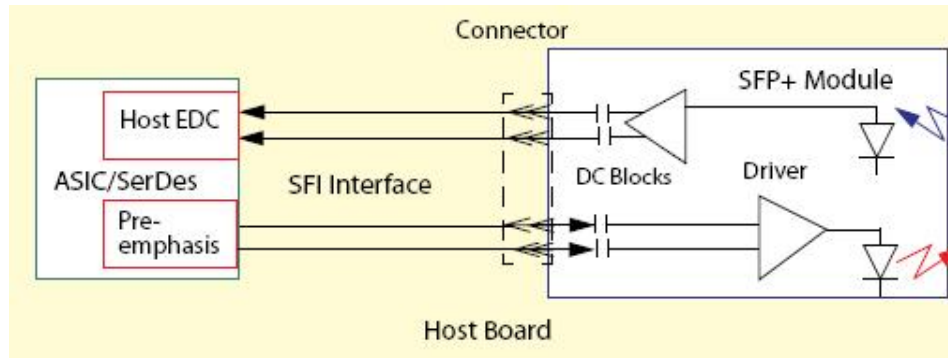

Figure 1: Interface to Host

Pin definition

The SFP+ modules are hot-pluggable. Hot pluggable refers to plugging in or unplugging a module while the host board is powered. The SFP+ host connector is a 0.8 mm pitch 20 position right angle improved connector specified by SFF-8083, or stacked connector with equivalent electrical performance. Host PCB contact assignment is shown in Figure 2 and contact definitions are given in Table 2. SFP+ module contacts mates with the host in the order of ground, power, followed by signal as illustrated by Figure 3 and the contact sequence order listed in Table 2.

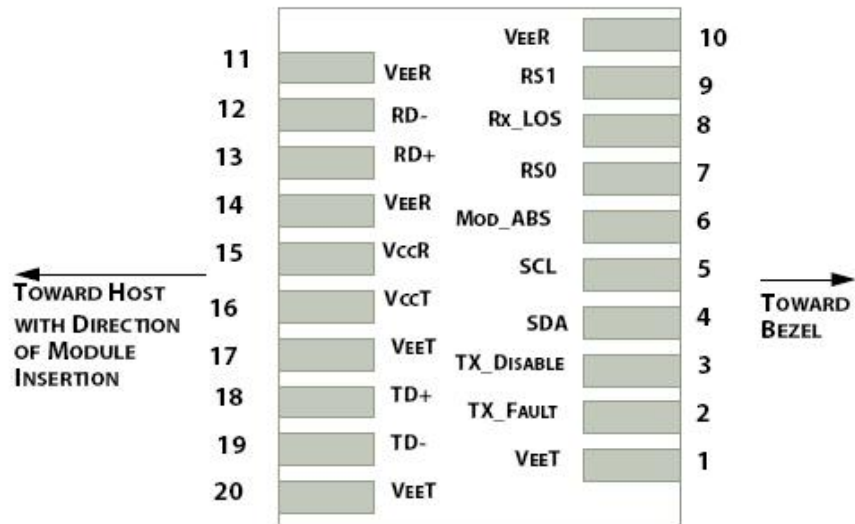

Figure 2: Interface to Host PCB



Figure 3: Module Contact Assignment

<i>Contacts</i>	<i>logic</i>	<i>Symbol</i>	<i>Power Sequence Order</i>	<i>Name/Description</i>
1		VeeT	1st	Module Transmitter Ground
2	LVTTL-O	TX_Fault	3rd	Module Transmitter Fault
3	LVTTL-I	TX_Disable	3rd	Transmitter Disable; Turns off transmitter laser output
4	LVTTL-I/O	SDA	3rd	2-wire Serial Interface Data Line (Same as MOD-DEF2 in the INF-8074i)
5	LVTTL-I/O	SCL	3rd	2-wire Serial Interface Clock (Same as MOD-DEF1 in the INF-8074i)
6		Mod_ABS	3rd	Module Absent, connected to VeeT or VeeR in the module
7	LVTTL-I	RS0	3rd	Rate Select 0, optionally controls SFP+ module receiver. When high input signaling rate > 4.25 GBd and when low input signaling rate ≤ 4.25 GBd.
8	LVTTL-O	Rx_LOS	3rd	Receiver Loss of Signal Indication (In FC designated as Rx_LOS and in Ethernet designated as <u>Signal Detect</u>)
9	LVTTL-I	RS1	3rd	Rate Select 1, optionally controls SFP+ transmitter. When high input signaling rate > 4.25 GBd and when low input signaling rate ≤ 4.25 GBd.
10		VeeR	1st	Module Receiver Ground
11		VeeR	1st	Module Receiver Ground
12	CML-O	RD-	3rd	Receiver Inverted Data Output
13	CML-O	RD+	3rd	Receiver Non-Inverted Data Output
14		VeeR	1st	Module Receiver Ground
15		VccR	2nd	Module Receiver 3.3 V Supply
16		VccT	2nd	Module Transmitter 3.3 V Supply
17		VeeT	1st	Module Transmitter Ground
18	CML-I	TD+	3rd	Transmitter Non-Inverted Data Input
19	CML-I	TD-	3rd	Transmitter Inverted Data Input
20		VeeT	1st	Module Transmitter Ground

Table 2: SFP+ Module PIN Definition

Absolute maximum rating

These values represent the damage threshold of the module. Stress in excess of any of the individual Absolute Maximum Ratings can cause immediate catastrophic damage to the module even if all other parameters are within Recommended Operating Conditions.

Parameters	Symbol	Min.	Max.	Unit
Power Supply Voltage	VCC	0	+3.6	V
Storage Temperature	Tc	-40	+85	°C

Operating Case Temperature	Tc	0	+70	°C
Relative Humidity	RH	5	95	%
RX Input Average Power	Pmax	-	0	dBm

Table 3: Absolute Maximum Rating

Recommended operating environment

Recommended Operating Environment specifies parameters for which the electrical and optical characteristics hold unless otherwise noted.

Parameter	Symbol	Min.	Typical	Max	Unit
Power Supply Voltage	VCC	3.135	3.300	3.465	V
Operating Case Temperature	TC	0	25	70	°C

Table 4: Recommended Operating Environment

Optical characteristics

The following optical characteristics are defined over the Recommended Operating Environment unless otherwise specified.

	Unit	Values	
Operating Reach	m	10K	
Transmit			
Center wavelength (range)	nm	1260 -1355	
Side Mode Suppression Ratio (min)	dB	30	
Launched power			
– maximum	dBm	+0.5	
– minimum	dBm	-8.2	Notes1
OMA	dBm	-5.2	
OMA-TDP (min)	dBm	-6.2	
Transmitter and dispersion penalty	dB	0	Notes4
Average launch power of OFF transmitter (max)	dBm	-30	
Extinction ratio (min)	dB	3.5	Notes2

RIN ₁₂ OMA (max)	dB/Hz	-128
Optical Return Loss Tolerance (min)	dB	12
Receiver		
Center wavelength (range)	nm	1260-1355
Receive overload (max) in average power ¹	dBm	0.5
Receive sensitivity (min) in average power ¹	dBm	-14.4 Notes ³ (10km)
	dBm	-13.4 Notes ³ (20km)
Receiver sensitivity (max) in OMA (footnote 2)	dBm	-12.6 Notes ³ (10km)
	dBm	-11.6 Notes ³ (20km)
Receiver Reflectance (max)	dB	-12
Stressed receiver sensitivity (max) in OMA ²	dBm	-10.3
Vertical eye closure penalty (min) ³	dB	2.2
Stressed eye jitter (min) ²	UIp-p	0.7
Receive electrical 3dB upper cutoff frequency (max)	GHz	12.3
Receiver power (damage, Max)	dBm	1.5
Notes: The optical power is launched into SMF Measured with a PRBS 231-1 test pattern@10.3125Gbps Measured with a PRBS 231-1 test pattern@10.3125Gbps BER ≤ 10 ⁻¹² 4. In G.652 and G.655(NDSF)		

Table 5: Optical Characteristics

Electrical characteristics

The following electrical characteristics are defined over the Recommended Operating Environment unless otherwise specified.

Parameter	Symbol	Min.	Typical	Max	Unit	Notes
Data Rate		-	10.3125	-	Gbps	
Power Consumption		-	1200	1500	mW	
Transmitter						

Single Ended Output Voltage Tolerance		-0.3	-	4.0	V	
C common mode voltage		15	-	-	mV	
Tx Input Diff Voltage	VI	400		1600	mV	
Tx Fault	VoL	-0.3		0.4	V	At 0.7mA
Data Dependent Input Jitter	DDJ			0.10	UI	
Data Input Total Jitter	TJ			0.28	UI	
Receiver						
Single Ended Output Voltage		-0.3	-	4.0	V	
Rx Output Diff Voltage	Vo	300		850	mV	
Rx Output Rise and Fall Time	Tr/Tf	30			ps	20% to 80%
Total Jitter	TJ			0.70	UI	
Deterministic Jitter	DJ			0.42	UI	

Table 6: Electrical Characteristics

Control and status I/O timing characteristics

Timing characteristics of control and status I/O are included in Table 7, which is also defined in SFF-8431.

<i>Parameter</i>	<i>Symbol</i>	<i>Min.</i>	<i>Max.</i>	<i>Unit</i>	<i>Conditions</i>
TX_Disable assert time	t_off		100	μs	rising edge of TX_Disable to fall of output signal below 10% of nominal
TX_Disable negate time	t_on		2	ms	Falling edge of Tx_Disable to rise of output signal above 90% of nominal. This only applies in normal operation, not during start up or fault recovery.
Time to initialize 2-wire interface	t_2w_start_up		300	ms	From power on or hot plug after the supply meeting Table 8 .
Time to initialize	t_start_up		300	ms	From power supplies meeting Table 8 or hot plug or Tx disable negated during power up, or Tx_Fault recovery, until non-cooled power level I part (or non-cooled power level II part already enabled at power level II for Tx_Fault recovery) is fully operational.
Time to initialize cooled module	t_start_up_cooled		90	s	From power supplies meeting Table 8 or hot plug, or Tx disable negated during power up or Tx_Fault recovery, until cooled power level I part (or cooled power level II part during fault recovery) is fully operational.
Time to Power Up to Level II	t_power_level2		300	ms	From falling edge of stop bit enabling power level II until non-cooled module is fully operational
Time to Power Down from Level II	t_power_down		300	ms	From falling edge of stop bit disabling power level II until module is within power level I requirements
TX_Fault assert	TX_Fault_on		1	ms	From occurrence of fault to assertion of TX_Fault
TX_Fault assert for cooled module	TX_Fault_on_cooled		50	ms	From occurrence of fault to assertion of TX_Fault
TX_Fault Reset	t_reset	10		μs	Time TX_Disable must be held high to reset TX_Fault
RS0, RS1 rate select timing for FC	t_RS0_FC, RS1_FC		500	μs	From assertion till stable output
RS0, RS1 rate select timing non FC	t_RS0, t_RS1		10	ms	From assertion till stable output
Rx_LOS assert delay	t_los_on		100	μs	From occurrence of loss of signal to assertion of Rx_LOS
Rx_LOS negate delay	t_los_off		100	μs	From occurrence of presence of signal to negation of Rx_LOS

Table 7: Timing Characteristics

Mechanical

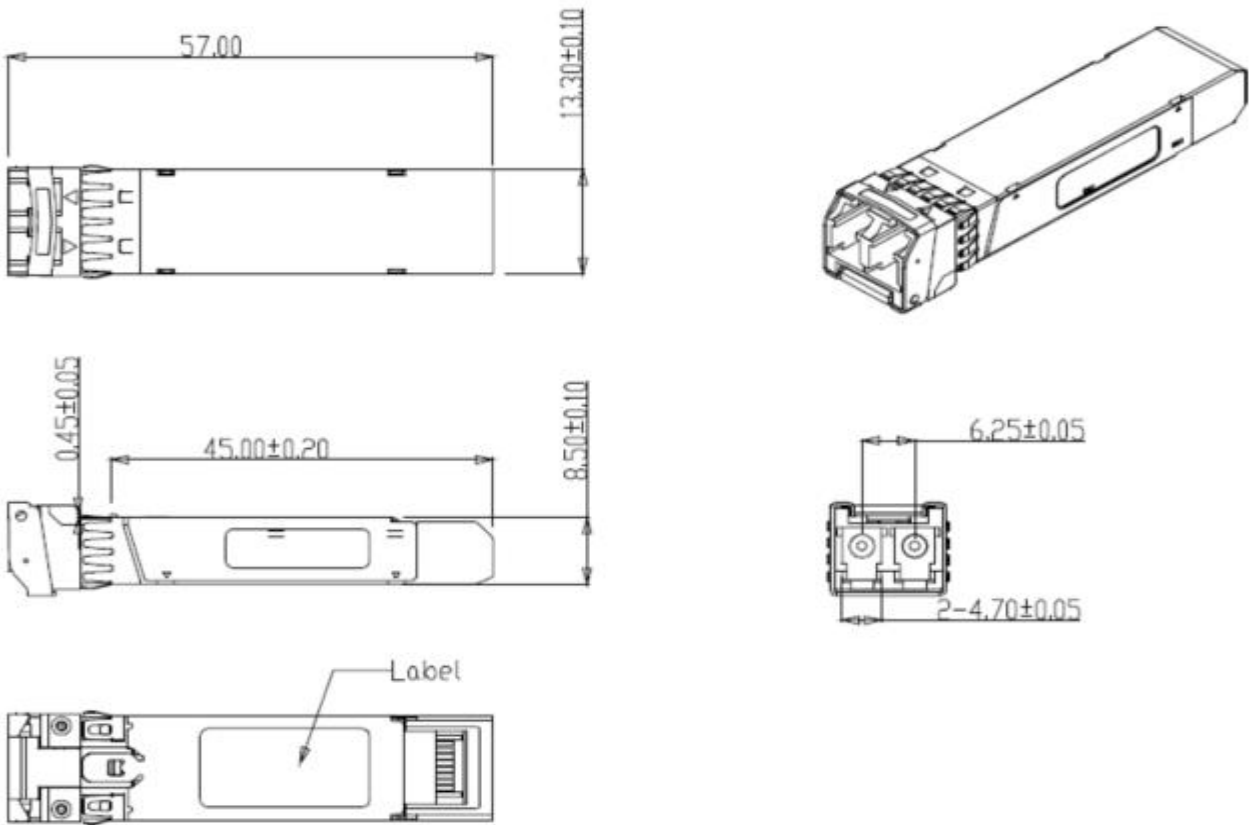

Table 8: Key Mechanical Dimensions

ESD

This transceiver is specified as ESD threshold 1kV for high speed pins and 2kV for all other electrical input pins, tested per MIL-STD-883, Method 3015.4 /JESD22-A114-A (HBM). However, normal ESD precautions are still required during the handling of this module. This transceiver is shipped in ESD protective packaging. It should be removed from the packaging and handled only in an ESD protected environment.

LASER SAFTY

This is a Class 1 Laser Product according to IEC 60825-1:1993:+A1:1997+A2:2001. This product complies with 21 CFR 1040.10 and 1040.11 except for deviations pursuant to Laser Notice No. 50, dated (July 26, 2001)